



---

**on tv & online**

# EDI 850 Purchase Order

ANSI Standard Version 4010

Revision: June 19,2000

For Warehouse Fulfillment Only

850oRT41

**SEGMENT ISA - INTERCHANGE CONTROL HEADER**

**PURPOSE**

To start and identify an interchange of one or more functional groups and interchange-related control segments.

**EDI STANDARD SEGMENT**

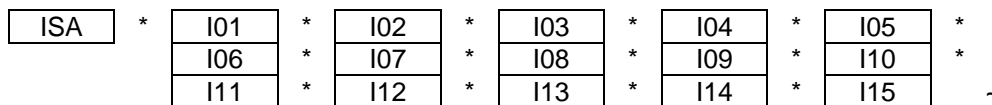

**HSN SUBSET OF EDI STANDARD SEGMENT**

Same as the EDI Standard Segment

ELEMENT NUMBER	ELEMENT NAME/DESCRIPTION	ELEMENT ATTRIBUTES	COMMENTS
ISA	<b>SEGMENT IDENTIFIER</b>		"ISA"
I01 001	<b>AUTHORIZATION INFORMATION QUALIFIER</b> Code to identify the type of information in the Authorization Information.	(M IS 2/2)	" 00 "
I02 002	<b>AUTHORIZATION INFORMATION</b> Information used for additional identification or authorization of the sender or the data in the interchange.	(M AN 10/10)	Blank
I03 003	<b>SECURITY COMMUNICATION QUALIFIER</b> Code to identify the type of information in the Security Information.	(M ID 2/2)	" 00 "
I04 004	<b>SECURITY INFORMATION</b> This is used for identifying the security information about the sender of the data in the interchange.	(M AN 10/10)	Blank

**Warehouse Fulfillment**

850oRT41

<b>105 005</b>	<b>INTERCHANGE ID QUALIFIER</b> Qualifier to designate the system/method of code structure used to designate the sender or receiver ID element being qualified.	(M ID 2/2)	HSN interchange qualifier. " 12 "
<b>106 006</b>	<b>INTERCHANGE SENDER ID</b> Identification code published by the sender for other parties to use as the receiver ID to route data to them. The sender always codes this number in the sender ID element.	(M ID 15/15)	HSN interchange ID. " 8135728585 "  "8135728585T" (for testing)
<b>105 007</b>	<b>INTERCHANGE ID QUALIFIER</b> Qualifier to designate the system/method of code structure used to designate the sender or receiver ID element being qualified.	(M ID 2/2)	Your interchange qualifier.
<b>107 008</b>	<b>INTERCHANGE RECEIVER ID</b> Identification code published by the sender for other parties to use as the receiver ID to route data to them.	(M ID 15/15)	Your interchange ID.
<b>108 009</b>	<b>INTERCHANGE DATE</b> Date of the interchange.	(M DT 6/6)	Interchange creation date (YYMMDD)
<b>109 010</b>	<b>INTERCHANGE TIME</b> Time of the interchange	(M TM 4/4)	Interchange creation time. HHMM
<b>110 011</b>	<b>INTERCHANGE CONTROL STANDARDS IDENTIFIER</b> Code to identify the agency responsible for the control standard used..	(M ID 1/1)	" U "
<b>111 012</b>	<b>INTERCHANGE CONTROL VERSION NUMBER</b> Version number covers the interchange control segments and functional group control segments.	((M ID 5/5)	" 00401 "
<b>112 013</b>	<b>INTERCHANGE CONTROL NUMBER</b> The number uniquely identifies the interchange data to the sender.	(M NO 9/9)	HSN sequential number

**Warehouse Fulfillment**

---

850oRT41

<b>I13</b> <b>014</b>	<b>ACKNOWLEDGMENT REQUESTED</b> Code sent to request an interchange acknowledgment.	(M ID 1/1)	" 0 "
<b>I14</b> <b>015</b>	<b>TEST INDICATOR</b> Code to indicate whether data enclosed by this interchange envelope is test or production.	(M ID 1/1)	" P " = production " T " = test
<b>I15</b> <b>016</b>	<b>SUB ELEMENT SEPARATOR</b>	(M AN 1/1)	" > "

**HSN Request you use a ~ 7E Segment Terminator**

850oRT41

**SEGMENT GS - FUNCTION GROUP HEADING**

**PURPOSE**

To indicate the beginning of a functional group and to provide control information.

**EDI STANDARD SEGMENT**

GS	*	479	*	142	*	124	*	29	*	30	*	28	*
		455	*	480		~							

**HSN SUBSET OF EDI STANDARD SEGMENT**

Same as the EDI Standard Segment.

ELEMENT NUMBER	ELEMENT NAME/DESCRIPTION	ELEMENT ATTRIBUTES	COMMENTS
GS	<b>SEGMENT IDENTIFIER</b>		"GS"
479 001	<b>FUNCTIONAL IDENTIFIER CODE</b> Code identifying a group of application related Transaction Sets.	(M ID 2/2)	" PO "
142 002	<b>APPLICATION SENDER'S CODE</b> Code identifying sending party.	(M AN 2/15)	HSN interchange ID " 8135728585 "
124 003	<b>APPLICATION RECEIVER'S CODE</b> Code identifying receiving party.	(M AN 2/15)	"8135728585T" (for testing) Your interchange ID.
29 004	<b>GROUP DATE</b> Date sender generated a group of transaction sets.	(M DT 8/8)	System date when group was created (CCYYMMDD).
30 005	<b>GROUP TIME</b> Time when the sender generated a functional group of transaction sets	(M TM 4/4)	Local time when group was generated (HHMM).
28 006	<b>GROUP CONTROL NUMBER</b> Assigned number originated and maintained by the sender.	(M ID 1/9)	HSN sequential number
455 007	<b>RESPONSIBLE AGENCY CODE.</b> Code used in conjunction with Data Element 480 to identify the issuer of the standard.	(M ID 1/2)	" X " for ASC X12.

NOTE REGARDING THE COMMENTS FIELD: Actual values are contained within quotes

**Warehouse Fulfillment**

---

850oRT41

480  
008

**VERSION/RELEASE/INDUSTRY  
ID CODE**  
Version and release information of  
the EDI standard being used.

(M ID 1/12)

“ 004010 “  
version number

---

850oRT41

**SEGMENT ST - TRANSACTION SET HEADER**

**PURPOSE**

To indicate the start of a transaction set and to assign a control number.

**EDI STANDARD SEGMENT**

ST	*	143	*	349	~
----	---	-----	---	-----	---

**HSN SUBSET OF EDI STANDARD SEGMENT**

Same as EDI Standard Segment above.

<b>ELEMENT NUMBER</b>	<b>ELEMENT NAME/DESCRIPTION</b>	<b>ELEMENT ATTRIBUTES</b>	<b>COMMENTS</b>
<b>ST</b>	<b>SEGMENT IDENTIFIER</b>		"ST"
<b>143 001</b>	<b>TRANSACTION SET IDENTIFIER CODE</b> Code uniquely identifying a transaction set.	(M AN 3/3)	"850"
<b>329 002</b>	<b>TRANSACTION SET CONTROL NUMBER</b> Identifying control number assigned by the originator for a transaction set.	(M AN 4/9)	Unique control number identifying a Transaction.

**Warehouse Fulfillment**

850oRT41

**SEGMENT BEG - BEGINNING SEGMENT FOR PURCHASE ORDER**

**PURPOSE**

To indicate the beginning of the purchase order transaction set and transmit identifying numbers and dates.

**EDI STANDARD SEGMENT**

BEG	*	353	*	92	*	324	*	328	*	
		323	*	367	*	587	*	1019	*	~

**HSN SUBSET OF EDI STANDARD SEGMENT**

BEG	*	353	*	92	*	324	*	328	*	373		~
-----	---	-----	---	----	---	-----	---	-----	---	-----	--	---

ELEMENT NUMBER	ELEMENT NAME/DESCRIPTION	ELEMENT ATTRIBUTES	COMMENTS
<b>BEG</b>	<b>SEGMENT IDENTIFIER</b>		"BEG"
<b>353 001</b>	<b>TRANSACTION SET PURPOSE CODE</b> Code identifying purpose of transaction set.	(M ID 2/2)	" 00 " = Original " 01 " = Cancellation " 04 " = Change
<b>92 002</b>	<b>PURCHASE ORDER TYPE CODE</b> Code specifying the type of P O	(M ID 2/2)	" SA "
<b>324 003</b>	<b>PURCHASE ORDER NUMBER</b> Identifying number assigned by the orderer/purchaser.	(M AN 1/22)	<b>HSN</b> Purchase order number (Length ≤ 10)
<b>328 004</b>	<b>RELEASE NUMBER</b> Number identifying a release against a Purchase Order .	(O AN 1/30)	"NOT USED"
<b>373 005</b>	<b>PURCHASE ORDER DATE</b> Date assigned by the purchaser to the Purchase Order.	(M DT 8/8)	<b>HSN</b> Order Date (CCYYMMDD)



850oRT41

**SEGMENT FOB – FOB RELATED INSTRUCTIONS**

**PURPOSE**

To specify identifying numbers.

**EDI STANDARD SEGMENT**

FOB	*	146	*	309	*	352	*	334	*	335	*
		309	*	352	*	54	*	352	~		

**HSN SUBSET OF EDI STANDARD SEGMENT**

FOB	*	146	*	309	*	352	~
-----	---	-----	---	-----	---	-----	---

ELEMENT NUMBER	ELEMENT NAME/DESCRIPTION	ELEMENT ATTRIBUTES	COMMENTS
FOB	SEGMENT IDENTIFIER		"FOB"
146 001	SHIPMENT METHOD OF PAYMENT Code specifying payment terms for transportation charges.	(M ID 2/2)	"CC" = Collect "PP" = Pre-Paid by Buyer
309 002	LOCATION QUALIFIER Code identifying type of location referencing FOB03.	(C ID 1/2)	"NS" = City/State from Points
352 003	DESCRIPTION A free form description to clarify the related data elements and their content.	(O AN 1/80)	City and State of Point of Departure.

**Warehouse Fulfillment**

850oRT41

**SEGMENT ITD – TERMS OF SALE**

**PURPOSE**

Terms of Sale/Deferred Terms of Sale.

**EDI STANDARD SEGMENT**

ITD	*	336	*	333	*	338	*	370	*	351	*	446	*
		386	*	362	*	388	*	389	*	342	*	352	*
		765	*	107	*	954	~						

**HSN SUBSET OF EDI STANDARD SEGMENT**

ITD	*	336	*	333	*	338	*	370	*	446	*	386	*
		362	~										

ELEMENT NUMBER	ELEMENT NAME/DESCRIPTION	ELEMENT ATTRIBUTES	COMMENTS
ITD	SEGMENT IDENTIFIER		" ITD "
336 001	TERMS TYPE CODE Code identifying type of payment terms.	(O ID 2/2)	" ZZ "
333 002	TERMS BASIS DATE CODE Code identifying the beginning of the terms period (1=shipdate, 2=delivery date, 3=invoice date)	(O ID 1 /2)	" 2 "
338 003	TERMS DISCOUNT PERCENT	(O R 1/6)	"NOT USED"
370 004	TERMS DISCOUNT DUE DATE	(C DT 8/8)	"NOT USED"
351 005	TERMS DISCOUNT DAYS DUE	(C N0 1/3)	"NOT USED"
446 006	TERMS NET DUE DATE	(O DT 8/8)	"NOT USED"
386 007	TERMS NET DAYS	(O N0 1/3)	"NOT USED"
362 008	TERMS DISCOUNT AMOUNT	(O N2 1/10)	"NOT USED"
388 009	TERMS DEFERRED DUE DATE	(O DT 6/6)	"NOT USED"
389 010	DEFERRED AMOUNT DUE	(C N2 1/10)	"NOT USED"

**Warehouse Fulfillment**

---

850oRT41

342 011	<b>PERCENT OF INVOICE PAYABLE</b>	(C R 1/5)	"NOT USED"
352 012	<b>DESCRIPTION</b> Free form description of terms	(O AN 1/80)	Terms of Sale
765 013	<b>DAY OF MONTH</b>	(C NO 1/2)	"NOT USED"
107 014	<b>PAYMENT METHOD CODE</b>	(O ID 1/1)	"NOT USED"
954 015	<b>PERCENT</b>	(O R 1/10)	"NOT USED"

850oRT41

**SEGMENT DTM – DATE/TIME REFERENCE**

**PURPOSE**

To specify identifying numbers.

**EDI STANDARD SEGMENT**

DTM \* 374 \* 373 \* 337 \* 623 \* 624 ~

**HSN SUBSET OF EDI STANDARD SEGMENT**

DTM \* 374 \* 373 ~

ELEMENT NUMBER	ELEMENT NAME/DESCRIPTION	ELEMENT ATTRIBUTES	COMMENTS
DTM	SEGMENT IDENTIFIER		"DTM"
374 001	DATE/TIME QUALIFIER Code specifying date and/or time.	(M ID 3/3)	" 010 " = Requested Ship Date
373 002	REFERENCE NUMBER Reference number or identification number as defined for a particular Transaction Set. or as specified by the Reference Number Qualifier.	(C DT 8/8)	<b>Date</b> CCYYMMDD

850oRT41

**SEGMENT N1 - NAME**

**PURPOSE**

To specify identifying numbers.

**EDI STANDARD SEGMENT**

N1
----

 \* 

98
----

 \* 

93
----

 \* 

66
----

 \* 

67
----

 ~

**HSN SUBSET OF EDI STANDARD SEGMENT**

N1
----

 \* 

128
-----

 \* 

127
-----

 \* 

66
----

 \* 

67
----

 ~

ELEMENT NUMBER	ELEMENT NAME/DESCRIPTION	ELEMENT ATTRIBUTES	COMMENTS
N1	SEGMENT IDENTIFIER		"N1"
98 001	ENTITY IDENTIFIER CODE	(M ID 2/3)	"VN" = Vendor
93 002	NAME Free form name.	(C AN 1/60)	Name of Vendor
66 003	IDENTIFICATION CODE QUALIFIER Reference number or identification number as defined for a particular Transaction Set. or as specified by the Reference Number Qualifier.	(C AN 1/2)	"92" = Assigned by Buyer
67 004	IDENTIFICATION CODE A free form description to clarify the related data elements and their content.	(C AN 2/80)	HSN Internal Vendor Number

850oRT41

**SEGMENT PO1 - PO BASELINE ITEM DETAIL**

**PURPOSE**

To specify basic and most frequently used line item data.

**EDI STANDARD SEGMENT**

PO1	*	350	*	330	*	355	*	212	*	639	*
		235	*	234	*	235	*	234	*	235	*
		234	*	235	*	234	*	235	*	234	*
		235	*	234	*	235	*	234	*	235	*
		234	*	235	*	234	*	235	*	234	~

**HSN SUBSET OF EDI STANDARD SEGMENT**

PO1	*	350	*	330	*	355	*	235	*
		234	*	235	*	234	*	~	

ELEMENT NUMBER	ELEMENT NAME/DESCRIPTION	ELEMENT ATTRIBUTES	COMMENTS
PO1	<b>SEGMENT IDENTIFIER</b>		"PO1"
350 001	<b>ASSIGNED IDENTIFICATION</b> Alphanumeric characters assigned for differentiation within a transaction set.	(O AN 1/20)	PO Line Number
330 002	<b>QUANTITY ORDERED</b>	(C R 1/15)	<b>HSN</b> Item quantity
355 003	<b>UNIT OF MEASUREMENT CODE</b> Code specifying the units in which a value is being expressed.	(O ID 2/2)	"EA"
212 004	<b>UNIT PRICE</b> Price per unit of product.	(C R 1/17)	Unit Cost
639 005	<b>BASIS OF UNIT PRICE CODE</b> Code identifying the type of unit price for an item.	(O ID 2/2)	**NOT USED**
235 006	<b>PRODUCT/SERVICE ID QUALIFIER</b> Code identifying type of descriptive number in Product ID.	(O ID 2/2)	"VN" Vendor Item number

NOTE REGARDING THE COMMENTS FIELD: Actual values are contained within quotes

**Warehouse Fulfillment**

---

850oRT41

<b>234 007</b>	<b>PRODUCT/SERVICE ID</b> Identifying number for a product or service.	(C AN 1/48)	<b>HSN</b> vendor item number
<b>235 008</b>	<b>PRODUCT/SERVICE ID QUALIFIER</b> Code identifying type of descriptive number in Product ID.	(C ID 2/2)	<b>HSN</b> " IT " (Buyer's style number qualifier)
<b>234 009</b>	<b>PRODUCT/SERVICE ID</b> Identifying number for a product..	(C AN 1/48)	<b>HSN</b> HSN's Item number (Length = 15 maximum)
<b>235 010</b>	<b>PRODUCT/SERVICE ID QUALIFIER</b> Code identifying type of descriptive number in Product ID.	(C ID 2/2)	<b>HSN</b> " UP " Universal Product Code UPC
<b>234 011</b>	<b>PRODUCT/SERVICE ID</b> Identifying number for a product..	(C AN 1/48)	<b>HSN</b> UPC if available

850oRT41

**SEGMENT PID - PRODUCT/ITEM DESCRIPTION**

**PURPOSE**

To describe a product or process in coded or free form format.

**EDI STANDARD SEGMENT**

PID	*	349	*	750	*	559	*
		751	*	352	*	752	~

**HSN SUBSET OF EDI STANDARD SEGMENT**

PID	*	349	*	*	*	*	352	~
-----	---	-----	---	---	---	---	-----	---

ELEMENT NUMBER	ELEMENT NAME/DESCRIPTION	ELEMENT ATTRIBUTES	COMMENTS
PID	SEGMENT IDENTIFIER		"PID"
349 001	ITEM DESCRIPTION TYPE Code indicating the format of a description.	(M ID 1/1)	HSN " F "
352 005	DESCRIPTION A free form description to clarify the related data elements and their content.	(C AN 1/80)	HSN Item description (Max length = 40)



850oRT41

**SEGMENT SDQ - SPECIAL SERVICES**

**PURPOSE**

To specify special conditions or services associated with the purchased product.

**EDI STANDARD SEGMENT**

SDQ \* 355 \* 66 \* 67 \* 380 \*  
67 \* 380 ~

**HSN SUBSET OF EDI STANDARD SEGMENT**

SDQ \* 355 \* 66 \* 67 \* 380 \*  
67 \* 380 ~

ELEMENT NUMBER	ELEMENT NAME/DESCRIPTION	ELEMENT ATTRIBUTES	COMMENTS
SDQ	SEGMENT IDENTIFIER		"SDQ"
355 001	UNIT OF MEASUREMENT CODE Code specifying the units in which a value is being expressed	(M ID 2/2)	"EA"
66 002	IDENTIFICATION CODE QUALIFIER Code identifying the warehouse receiving the goods.	(O ID 1/2)	"92" = Assigned by buyer
67 003	IDENTIFICATION CODE Code identifying the warehouse receiving the goods	(M AN 2/80)	Salem = "97" Waterloo = "98" Showroom = "01" Jewelry = "99" Fontana = "96" RTW = "95"
380 004	QUANTITY Quantity	(M R 1/15)	Quantity
67 005	IDENTIFICATION CODE Code identifying the warehouse receiving the goods.	(C AN 2/80)	Salem = "97" Waterloo = "98" Showroom = "01" Jewelry = "99" Fontana = "96" RTW = "95" If being shipped to more than one warehouse

***Warehouse Fulfillment***

---

850oRT41

**380**      **QUANTITY**  
**006**      Quantity

(C R 1/15)

Quantity  
If being shipped to more than  
one warehouse

850oRT41

**SEGMENT TC2 – COMMODITY**

**PURPOSE**

To identify commodity or group of commodities.

**EDI STANDARD SEGMENT**

TC2 \* 23 \* 22 ~

**HSN SUBSET OF EDI STANDARD SEGMENT**

TC2 \* 23 \* 22 ~

ELEMENT NUMBER	ELEMENT NAME/DESCRIPTION	ELEMENT ATTRIBUTES	COMMENTS
TC2	SEGMENT IDENTIFIER		"TC2"
23 001	COMMODITY CODE QUALIFIER Code specifying commodity.	(M ID 1/1)	" Q " = Category
22 002	REFERENCE NUMBER Reference number or identification number as defined for a particular Transaction Set. or as specified by the Reference Number Qualifier.	(M AN 1/30)	HSN Product Category Code

**Warehouse Fulfillment**

---

850oRT41

**SEGMENT AMT – MONETARY AMOUNT**

**PURPOSE**

To specify identifying numbers.

**EDI STANDARD SEGMENT**

\*  \*   ~

**HSN SUBSET OF EDI STANDARD SEGMENT**

\*  \*  ~

<b>ELEMENT NUMBER</b>	<b>ELEMENT NAME/DESCRIPTION</b>	<b>ELEMENT ATTRIBUTES</b>	<b>COMMENTS</b>
<b>AMT</b>	<b>SEGMENT IDENTIFIER</b>		"AMT"
<b>522 001</b>	<b>AMOUNT CODE QUALIFIER</b> Address Information .	(M ID 1/3)	" 1 " = Line item Total
<b>782 002</b>	<b>MONETARY AMOUNT</b> Address Information.	(O N2 1/18)	Line Item Total

850oRT41

**SEGMENT CTT - TRANSACTION TOTALS**

**PURPOSE**

To transmit a hash total for a specific element in the transaction set.

**EDI STANDARD SEGMENT**

CTT \* 354 \* 347 \* 81 \*  
355 \* 183 \* 355 \* 352 ~

**HSN SUBSET OF EDI STANDARD SEGMENT**

CTT \* 354 \* 347 ~

ELEMENT NUMBER	ELEMENT NAME/DESCRIPTION	ELEMENT ATTRIBUTES	COMMENTS
CTT	SEGMENT IDENTIFIER		"CTT"
354 001	<b>NUMBER OF LINE ITEMS</b> Total number of line items in the transaction set.	(M N0 1/6)	Total number of line items in the transaction.
347 002	<b>HASH TOTAL</b> Sum of totals of the specified data element.	(O R 1/10)	Total number of line items in the transaction.
81 003	<b>WEIGHT</b> Numeric value of weight.	(C R 1/10)	**NOT USED**
355 004	<b>UNIT OF MEASUREMENT CODE</b> Code specifying the units in which a value is being expressed.	(C ID 2/2)	**NOT USED**
183 005	<b>VOLUME</b> Value of volumetric measure.	(C R 1/8)	**NOT USED**
355 006	<b>UNIT OF MEASUREMENT CODE</b> Code specifying the units in which a value is being expressed.	(C ID 2/2)	**NOT USED**
352 007	<b>DESCRIPTION</b> Free form description to clarify the related data elements and their content.	(O AN 1/80)	**NOT USED**

---

850oRT41

**SEGMENT SE - TRANSACTION SET TRAILER**

**PURPOSE**

To indicate the end of the transaction set and provide the count of the transmitted segments (including the beginning (ST) and the ending (SE) segments).

**EDI STANDARD SEGMENT**

SE \* 96 \* 329 ~

**HSN SUBSET OF EDI STANDARD SEGMENT**

Same as the EDI Standard Segment.

	<b>ELEMENT NAME/DESCRIPTION</b>	<b>ELEMENT ATTRIBUTES</b>	<b>COMMENTS</b>
<b>SE</b>	<b>SEGMENT IDENTIFIER</b>		"SE"
<b>96 001</b>	<b>NUMBER OF INCLUDED SEGMENTS</b> Total number of segments included in a transaction set including ST and SE segments.	(M NO 1/10)	
<b>329 002</b>	<b>TRANSACTION SET CONTROL NUMBER</b> Identifying control number that must be unique within the transaction set functional group assigned by the originator for a transaction set.	(M AN 4/9)	<b>HSN</b> Our sequential number

---

850oRT41

**SEGMENT GE - FUNCTIONAL GROUP TRAILER**

**PURPOSE**

To indicate the end of a functional group and to provide control.

**EDI STANDARD SEGMENT**

GE \* 97 \* 28 ~

**HSN SUBSET OF EDI STANDARD SEGMENT**

Same as EDI Standard Segment

	<b>ELEMENT NAME/DESCRIPTION</b>	<b>ELEMENT ATTRIBUTES</b>	<b>COMMENTS</b>
<b>GE</b>	<b>SEGMENT IDENTIFIER</b>		" GE "
<b>97 001</b>	<b>NUMBER OF TRANSACTION SETS INCLUDED.</b> Count of ST segments within the Group.	(M NO 1/6)	Total number of transaction sets included in the GS - GE group.
<b>28 002</b>	<b>GROUP CONTROL NUMBER</b> Assigned number originated and maintained by the sender.	(M NO 1/9)	Same number as in GS segment (data element 06)

---

850oRT41

**SEGMENT IEA - INTERCHANGE CONTROL TRAILER**

**PURPOSE**

To define the end of an interchange of one or more functional groups and interchange-related control segments.

**EDI STANDARD SEGMENT**

IEA \* I16 \* I12 ~

**HSN SUBSET OF EDI STANDARD SEGMENT**

Same as EDI Standard Segment.

	<b>ELEMENT NAME/DESCRIPTION</b>	<b>ELEMENT ATTRIBUTES</b>	<b>COMMENTS</b>
<b>IEA</b>	<b>SEGMENT IDENTIFIER</b>		" IEA "
<b>I16 001</b>	<b>NUMBER OF INCLUDED FUNCTIONAL GROUPS</b> A count of the number of included groups included in a transmission.	(M NO 1/5)	Count of the GS segments in the transmission.
<b>I12 002</b>	<b>INTERCHANGE CONTROL NUMBER</b> Number that uniquely identifies the interchange data. It is assigned by the sender.	(M NO 9/9)	Same number as in the ISA segment (data element 13)



---

850oRT41  
**TRANSACTION LAYOUT**

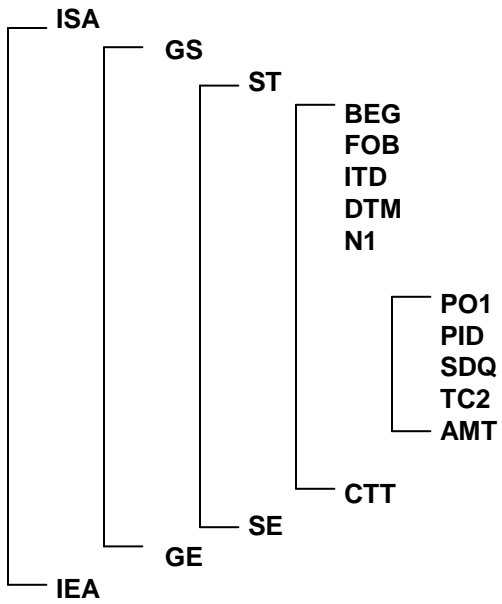

---

850oRT41

**SAMPLE TRANSACTION**

ISA\*00\* \*00\* \*12\*8135728585 \*01\*999920703  
\*000509\*1912\*U\*00401\*000000393\*0\*P\*>  
GS\*PO\*8135728585\*999920703\*20000509\*1912\*000000393\*X\*004010  
ST\*850\*0001  
BEG\*00\*SA\*697795\*\*20000424  
FOB\*PP\*NS\*NEW YORK NY  
ITD\*ZZ\*2\*\*\*\*\*N30  
DTM\*010\*20000515  
N1\*VN\*CLEAN CORPORATION\*92\*095774  
PO1\*1\*50\*EA\*245.35\*\*VN\*PAN637675\*IT\*190457  
PID\*F\*\*\*\*14K LINK STAMPATO BRAC 7.5"  
SDQ\*EA\*92\*99\*50  
TC2\*Q\*234  
AMT\*1\*1226750  
PO1\*2\*125\*EA\*91.42\*\*VN\*HLO520772\*IT\*190458  
PID\*F\*\*\*\*14K POL ONDA BRAC 7.25"  
SDQ\*EA\*92\*99\*125  
TC2\*Q\*234  
AMT\*1\*1142750  
PO1\*3\*150\*EA\*74.56\*\*VN\*GCH253900\*IT\*190459  
PID\*F\*\*\*\*14K POL CURB LINK BRAC  
SDQ\*EA\*92\*99\*150  
TC2\*Q\*234  
AMT\*1\*1118400  
PO1\*4\*175\*EA\*18.78\*\*VN\*GCH253900\*IT\*212449702  
PID\*F\*\*\*\*14K OPEN SATIN HEART PND YELLOW  
SDQ\*EA\*92\*99\*175  
TC2\*Q\*234  
AMT\*1\*328650  
PO1\*5\*75\*EA\*18.78\*\*VN\*GCH253900\*IT\*212449100  
PID\*F\*\*\*\*14K OPEN SATIN HEART PND WHITE  
SDQ\*EA\*92\*99\*75  
TC2\*Q\*234  
AMT\*1\*140850  
PO1\*6\*35\*EA\*206.2\*\*VN\*OMA113511\*IT\*190475  
PID\*F\*\*\*\*14K OMEGA NECKLACE 17"  
SDQ\*EA\*92\*99\*35  
TC2\*Q\*234  
AMT\*1\*721700  
PO1\*7\*15\*EA\*242.32\*\*VN\*TBD\*IT\*190477  
PID\*F\*\*\*\*14K OMEGA NECKLACE 20"  
SDQ\*EA\*92\*99\*15  
TC2\*Q\*234  
AMT\*1\*363480  
PO1\*8\*300\*EA\*28.1\*\*VN\*GEG284600\*IT\*190525  
PID\*F\*\*\*\*14K POL PEAR DROP EARRINGS  
SDQ\*EA\*92\*99\*300  
TC2\*Q\*234  
AMT\*1\*843000  
CTT\*8  
SE\*48\*0001  
ST\*850\*0002  
BEG\*00\*SA\*697840\*\*20000425

---

**850oRT41**

FOB\*PP\*NS\*NEW YORK NY  
ITD\*ZZ\*2\*\*\*\*\*N30  
DTM\*010\*20000508  
N1\*VN\*CLEAN CORPORATION\*92\*095774  
PO1\*1\*340\*EA\*40.68\*\*VN\*HBS154218\*IT\*284075  
PID\*F\*\*\*\*14K HERRINGBONE NK 18"  
SDQ\*EA\*92\*99\*340  
TC2\*Q\*235  
AMT\*1\*1383120  
PO1\*2\*235\*EA\*41.35\*\*VN\*HBS230920\*IT\*229479  
PID\*F\*\*\*\*14K 3MM POLISH H'BONE NK 20"  
SDQ\*EA\*92\*99\*235  
TC2\*Q\*235  
AMT\*1\*971725  
PO1\*3\*385\*EA\*52.05\*\*VN\*HBS154224\*IT\*284078  
PID\*F\*\*\*\*14K HERRINGBONE NK 24"  
SDQ\*EA\*92\*99\*385  
TC2\*Q\*235  
AMT\*1\*2003925  
PO1\*4\*285\*EA\*16.84\*\*VN\*SIN143020\*IT\*284082702  
PID\*F\*\*\*\*14K SINGAPORE NK 20" YELLOW  
SDQ\*EA\*92\*99\*285  
TC2\*Q\*235  
AMT\*1\*479940  
PO1\*6\*115\*EA\*22.67\*\*VN\*SIN143022\*IT\*284081702  
PID\*F\*\*\*\*14K SINGAPORE NK 22" YELLOW  
SDQ\*EA\*92\*99\*115  
TC2\*Q\*235  
AMT\*1\*260705  
CTT\*5  
SE\*33\*0002  
GE\*2\*000000393  
IEA\*1\*000000393